

HACKERS KING OF THE HILL

Hackers King of the Hill is a new event for Hackers players to participate in between and after their tournament games. The Hackers King of the Hill entry fee is \$3 per player. Hackers King of the Hill is composed of three contests. The time duration for each of these contests per player will be very short. The player with the lowest cumulative score from all three contests is the Hackers King of the Hill. The winning players in each age division will receive a championship award and a Hackers King of the Hill t-shirt. This event is for all ages just like the Hackers 3v3.

Contest 1: Two-Player Passing Game

The first contest is a two-player passing game played on a 32 ft. x 32 ft. grid (see Figure 1 below). The two player team with the lowest score is the winner. Each team must complete 17 passes moving in a clock wise direction and then must complete 16 passes moving in a counter clock wise direction. The team's score is composed of the elapsed time of the team to initiate its first pass until the completion of its last pass plus penalties. Each player on the team is credited with the same score. Read this document (Appendix A below) for description of the Two-Person Passing Grid Game, penalties and the scoring process.

Figure 1. Passing & Shooting Grid

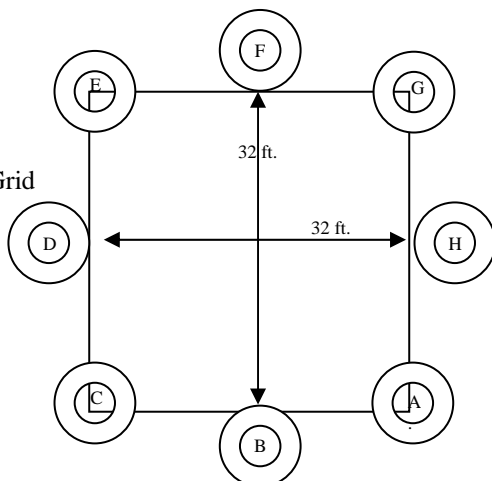

First Round Procedure:

Each team in the first round will compete in an abbreviated version of the full grid game. The time allocated to each team in the first round is 30 seconds.

Semi-Finals & Championship Procedure:

Teams in the semi-final and the championship final will complete the entire grid game. Maximum time anticipated per team is three minutes for the semi-final round and the championship final. All but four teams will be eliminated in the first round. Two teams will be eliminated in the semi-final round.

See Appendix A for Contest 1 Game Procedures & Scoring Rules.

Contest 2: One-Player Shooting Game

The second contest is a one-player shooting game played on a 32 ft. x 32 ft. grid (see field diagram below). The player with the lowest score is the winner. Each player must complete 9 shots moving in a clock wise direction and then must complete 8 shots moving in a counter clock wise direction. The player's score is composed of the elapsed time for the player to initiate/strike the first shot until the player strikes the last shot plus penalties. Read this document (see Appendix B) for description of the One-Person Shooting Grid Game, penalties and the scoring process.

First Round Procedure:

Each player in the first round will compete in an abbreviated version of the full grid game. The time allocated to each player in the first round is 30 seconds.

Semi-Finals & Championship Procedure:

Players in the semi-final and the championship final will complete the entire grid game. Maximum time anticipated per player is three minutes for the semi-final round and the championship final. All but four players will be eliminated in the first round. Two players will be eliminated in the semi-final round.

Field Diagram:

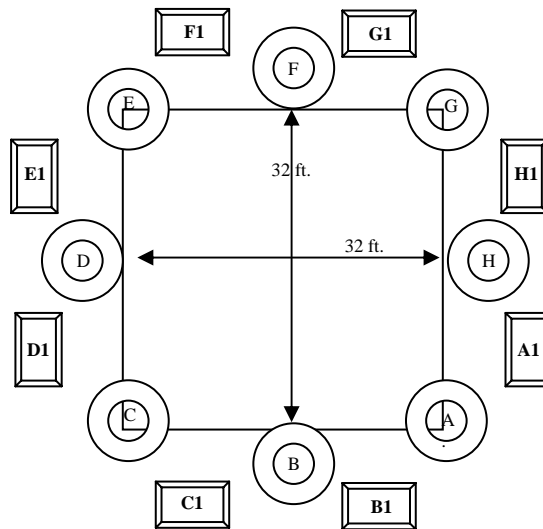

See Appendix B for Contest 2 Game Procedures & Scoring Rules.

Contest 3: Freestyle Street Soccer:

The third contest is an individual freestyle street soccer presentation by the player. Players in each round will be paired against another contestant. Each player in a pairing will have the ball for 30 seconds. The player judged to have the best presentation advances. Players will be judged on ball control, style and creativity.

Go to www.youtube.com and enter Red Bull Street Style Soccer in search for videos. Read this document (see Appendix C) for description of the scoring process. Here is a chance for contestants to show off for the crowd, their teammates and friends and most of all the judges. Don't worry about how you might look the first time because you are going to get better. The winner's video will be posted online at the Cutters Web site.

See Appendix C for Contest 3 Procedures & Scoring Rules.

Appendix A: Contest 1 Game Procedures & Scoring Rules

The corners (A, C, E & G) of the center square lie on a 32 ft. x 32 ft. grid. Refer to the diagram below. There are eight points (A, B, C, D, E, F, G, & H). Each of the eight points is surrounded by a 3 ft. diameter inner circle and a 6 ft. outer diameter. The centers of the eight points are all 16.5 ft. apart starting at point A going in a clockwise or a counter clockwise direction. Points B, D, F & H all lie at the mid-point of the four lines that connect points A, C, E & G and are located 4 ft. perpendicular from the mid-points.

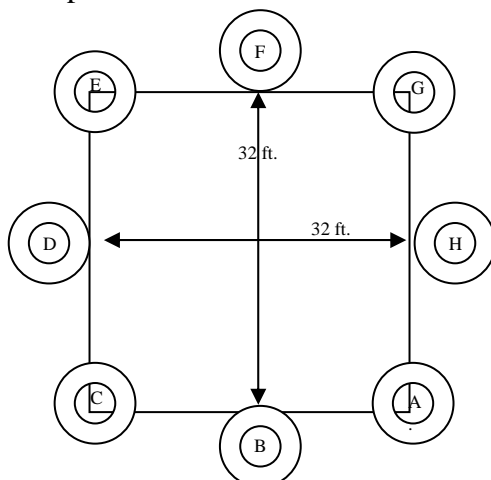

First Game Two-Person Passing Game Procedure

1. One of the two team players begins at point A (player 1) and passes to his/her teammate (player 2) located at point F.
2. Player 1 moves to point B after initiating the pass.
3. Player 2 (point F) receives the pass and then immediately passes to player 1 who has moved point B.
4. Player 2 moves to point G to receive the next pass from player 1.
5. This process continues in a clock wise direction until player 1 has returned to point A and completes a pass to player 2 at point F.
6. Player 1 then moves in a counter clockwise direction to point H.
7. Player 2 (point F) receives the pass then immediately passes to player 1 who has moved to point H.
8. Player 2 moves to point E to receive the next pass from player 1.
9. This process continues in a counter clock wise direction until player 1 has returned to point A and completes a pass to player 2 at point F.

First Game: Two Person Passing Game Scoring

- The team is competing against the clock.
- The team's time is the total elapsed time from the touch of the first pass to the trap of the last pass.
- In addition, any ball received between the inner circle and outer circle results in a penalty of three seconds that is added to the elapsed time.
- Any ball received outside of the outer circle results in a penalty of six that is added to the elapsed time.
- **Example:** So if a team has a time of 90 seconds for the passing, but traps 5 balls between the inner and outer circles of five points they will be penalized 15 seconds. If they have

an additional 3 balls outside the outer circles, they incur an additional penalty of 18 seconds. The total time is 90 + 15 + 18 which equals 123 seconds.

- Penalties occur for any ball received outside the inner circle. The goal is to receive all passes within the inner circle as there is no penalty added to elapsed time.
- **First Round:** The first round is abbreviated. Each team will have 30 seconds to complete as many passes as possible. An example is shown below. The team must complete the following passes.

CW	A-F; F-B; B-G; G-C; C-H; H-D; D-A; A-E; E-B; B-F; F-C; C-G; G-D; D-H; H-E; E-A; A-F
CCW	F-H; H-E; E-G; G-D; D-F; F-C; C-E; E-B; B-D; D-A; A-C; C-H; H-B; B-G; G-A; A-F

SCORING EXAMPLE

Two Player Passing Game

1st Round Scoring

Team	Passes	Time (sec)	Penalty (3 sec)	Penalty (6 sec)	Total Time	Score	Rank
1	15	30	7: 21	3: 18	69	=69/15=4.6	6 out
2	16	30	10: 30	2: 12	72	=72/16=4.5	5 out
3	17	30	6: 18	4: 24	72	=72/17=4.235	3 to 2 nd rd
4	17	30	5: 15	5: 30	75	=75/17=4.412	4 to 2 nd rd
5	17	30	6: 18	3: 18	66	=66/17=3.882	1 to 2 nd rd
6	17	30	5: 15	4: 24	69	=69/17=4.059	2 to 2 nd rd

1st round elimination: Top four advance to semi-finals (# of rounds) x 10 x time/score ranking =;

Team 1 Score: 6th place (3 rounds; 6th place in 1st round): 3 x 10 x 6 = 180

Team 2 Score; 5th place: (3 rounds; 5th place in 1st round): 3 x 10 x 5 = 150

2nd Round (semi-final) Scoring

Team	Passes	Time	Penalty (3)	Penalty (6)	Total Time	Score	Rank
3	33	150	10: 30	5: 30	210	=210/33=6.36	3 out
4	32	170	11: 33	6: 36	239	=239/32=7.469	4 out
5	33	135	6: 18	4: 24	177	=177/33=5.364	1 to 3 rd rd
6	33	140	5: 15	5: 30	185	=185/33=5.606	2 to 3 rd rd

Semi-final round elimination: Top two advance to finals (# of rounds – 1) x 10 x 2 =

Team 4 Score; 4th place: (3 rounds; 4th place in semi-final round): (3-1) x 10 x 4 =80

Team 3 Score: 3rd place: (3 rounds; 3rd place in semi-final round): (3-1) x 10 x 3 =60

3rd Round (final) Scoring

Team	Passes	Time	Penalty (3)	Penalty (6)	Total Time	Score	Rank
5	33	145	7: 21	4: 24	190	=190/33=5.758	1
6	33	147	5: 15	6: 36	198	=198/33=6.000	2

Final round elimination: (# of rounds – 2) x 10 x 2 =

Team 6 Score: Runner-up: (3-1) x 10 x 2 = 20

Team 5 Score: Champion: (3-1) x 10 x 1 = 10

Final Points

Team		Final Points
1	6 th place	180
2	5 th place	150
3	3 rd place	60
4	4 th place	80
5	1 st place	10 Team 5 wins with low score
6	2 nd place	20

Appendix B: Contest 2 Procedures & Scoring: One Player Shooting Game

Field Diagram:

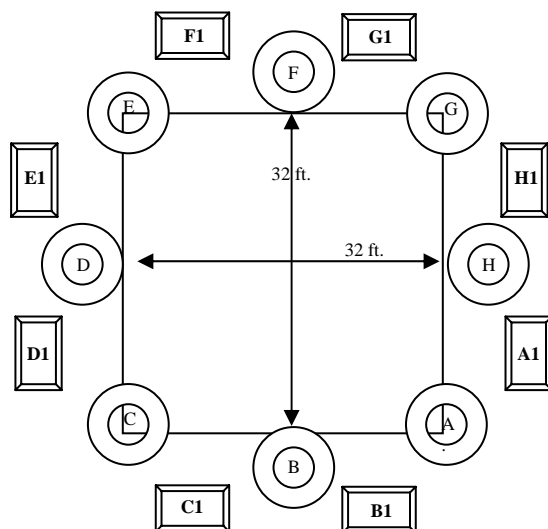

Image of Goal:



Procedure:

1. The player starts at point A.
2. The player shoots at a goal stationed at point F1.
(Best shot: between chair legs, second best: inside outer goal)
3. After the player strikes the shot at point F1, they move in a clockwise direction to point B to shoot at a goal stationed at point G1.
4. The player continues in a clockwise direction until they return to point A and complete a shot at point F1.
5. After the player strikes the shot at point F1, they move in a counter clockwise direction to point H to shoot at a goal stationed at point E1.
6. The player continues in a counter clockwise direction until they return to point A and completes a shot at point F1. The player is competing against the clock.
7. The player's time is the total elapsed time from the touch of the first shot to the touch of the last shot.

Penalties:

Any shot that fails to go into the inner goal adds penalties to the elapsed time.

- Any shot that misses the inner goal (chair legs in photo), but goes into the outer goal, adds 3 seconds to the elapsed time.
- Any shot that misses both the inner and outer goals adds 6 seconds to the elapsed time.
- **Example:** A player has an elapsed time of 70 seconds, and makes seven shots in the inner goal and makes four shots in the outer goal for a penalty of 12 seconds, misses six shots outside the outer goal for a penalty of 36 seconds. The player's total score is $70 + 12 + 36$ which equals 118 seconds.

First Round: The first round will be abbreviated. Each player will have 30 seconds to complete as many shots as possible. An example is shown below. The player attempts the following shots.

CW	A-F1; B-G1; C-H1; D-A1; E-B1; F-C1; G-D1; H-E1; A-F1
CCW	H-E1; G-D1; F-C1; E-B1; D-A1; C-H1; B-G1; A-F1

SCORING EXAMPLE

One Player Shooting Game

1st Round Scoring

Player	Shots	Time (sec)	Penalty (3 sec)	Penalty (6 sec)	Total Time	Score	Rank
1	9	30	2: 6	3: 18	54	$=54/9=6.000$	2: 2 nd rd
2	8	30	3: 9	2: 12	51	$=51/8=6.375$	4: 2 nd rd
3	8	30	2: 6	4: 24	60	$=60/8=7.5$	6: out
4	9	30	4:12	3: 18	60	$=60/9=6.667$	5: out
5	9	30	5:15	1: 6	51	$=51/9=5.667$	1: 2 nd rd
6	8	30	6:18	0: 0	48	$=48/8=6.000$	2: 2 nd rd

1st round elimination: Top four advance to semi-finals (# of rounds) x 10 x time/score ranking =;

Player 4 Score; 5th place: (3 rounds; 5th place in 1st round): $3 \times 10 \times 5 = 150$

Player 3 Score: 6th place (3 rounds; 6th place in 1st round): $3 \times 10 \times 6 = 180$

2nd Round (semi-final) Scoring

Player	Shots	Time (sec)	Penalty (3 sec)	Penalty (6 sec)	Total Time	Score	Rank
1	17	75	6: 18	4: 24	117	$=117/17=6.882$	4: out
2	17	72	7: 21	2: 12	105	$=105/17=6.176$	2: out
5	17	65	7: 21	1: 6	92	$=92/17=5.412$	1: 3 rd rd
6	17	69	5: 15	3: 18	102	$=102/17=6.000$	2: 3 rd rd

Player 6 made 9 shots in 69 seconds; Player 2 made 8 shots in 72 seconds; Player 6 advances.

Semi-final round elimination: Top two advance to finals (# of rounds – 1) x 10 x 2 =

Player 1 Score; 4th place: (3 rounds; 4th place in semi-final round): (3-1) x 10 x 4 =80

Player 2 Score: 3rd place: (3 rounds; 3rd place in semi-final round): (3-1) x 10 x 3 =60

3rd Round (final) Scoring

Player	Shots	Time (sec)	Penalty (3 sec)	Penalty (6 sec)	Total Time	Score	Rank
5	17	64	8: 24	1: 6	94	=94/17=5.529	1
6	17	65	7: 21	2: 12	98	=98/17=5.764	2

Final round elimination: (# of rounds – 2) x 10 x 2 =

Player 6 Score: Runner-up: (3-1) x 10 x 2 = 20

Player 5 Score: Champion: (3-1) x 10 x 1 = 10

Final Points

Team		Final Points
1	4 th place	80
2	3 rd place	60
3	6 th place	180
4	5 th place	150
5:	1 st place	10 Player 5 wins with low score
6:	2 nd place	20

Appendix C: Contest 3 Freestyle Game Procedures & Scoring Rules.

The third contest is an individual freestyle street soccer presentation by the player. Players in each round will be paired against another contestant. Each player in a pairing will have the ball for 30 seconds. The player judged to have the best presentation advances. Players will be judged on ball control, style and creativity.

SCORING EXAMPLE

Freestyle

Two contestants (Rob and Josh) are paired against each other. Judge #1 selects Rob for best ball control. Judge # 2 selects Josh for best style. Judge #3 selects Josh for best creativity. Josh advances because he won 2 of the 3 judging factors and Rob is eliminated. Players receive points based upon the round in which they are eliminated. Let's say that Rob is eliminated in the first round and there are four rounds of competition, his score for the freestyle is 80 points. All players eliminated in the first round of this example will receive a score of 80 for the freestyle.

Players will receive points as follows:

1st round elimination: (# of rounds) x 10 x 2 =; example (4 rounds): 4 x 10 x 2 = 80

2nd round elimination: (# of rounds - 1) x 10 x 2 = example (4 rounds): (4-1) x 10 x 2 =60

3rd round elimination: (# of rounds - 2) x 10 x 2 = example (4 rounds): (4-2) x 10 x 2 =40

Etc.

Final round elimination: Runner-up: 1 x 10 x 2 = 20

Champion: 1 x 10 x 1 = 10